

Ji J, Zheng X, He C, Zhang Z, Wang Y, Roskilly T.

[Experimental Study for a Micro Smart Grid to Meet the Energy Demand of a Household](#)

*In: 8th International Conference on Applied Energy (ICAE2016)*

8-11 October 2016, Beijing, China: Elsevier Ltd.

## Copyright

© 2017 The Authors. Published by Elsevier Ltd. This is an open access article under the CC BY license (<http://creativecommons.org/licenses/by/4.0/>). Peer review under responsibility of the scientific committee of the 8th International Conference on Applied Energy

DOI link to article:

<https://doi.org/10.1016/j.egypro.2017.03.418>

Date deposited:

18/07/2017



This work is licensed under a [Creative Commons Attribution-NonCommercial-NoDerivatives 4.0 International licence](http://creativecommons.org/licenses/by-nc-nd/4.0/)

The 8<sup>th</sup> International Conference on Applied Energy – ICAE2016

## Experimental study for a micro smart grid to meet the energy demand of a household

Jie Ji<sup>a\*</sup>, XiaoZheng<sup>b</sup>, Cui He<sup>b</sup>, Zhichao Zhang<sup>a</sup>, Yaodong Wang<sup>a</sup>, Tony Roskilly<sup>a</sup>

*a Sir Joseph Swan Centre for Energy Research, School of Mechanical and Systems Engineering, Newcastle University, Newcastle upon Tyne, NE1 7RU, UK*

*b Guangxi Electrical Power Institute of Vocational Training, Nanning Guangxi 530007, China*

### Abstract

In this research, a smart grid using renewable energy and energy storage unit is studied. The system's storage units applies novel supercapacitor technologies to work with traditional batteries. This study aims at satisfying the dynamic demand of a household and evaluate the performance of the smart grid. The system design and the control strategy design is expressed in the paper combined with the discussion of the system's operation theory. The control panel of the system use SIEMENS S7-200 PLC as the core chipset. Digital software is an auxiliary tool for monitoring the system's operation process. The controlling method is divided into two situations, with renewable energy source and without renewable energy source, and both the operation processes are presented in detail in the results discussion part. After analysing the operation details of the system, the controlling strategy is proven to be useful for the operation of the smart grid system. Future work for the system is combining the electrical smart grid with other energy source. This system is potentially to be developed as electrical part of a multi energy system.

© 2017 The Authors. Published by Elsevier Ltd. This is an open access article under the CC BY-NC-ND license (<http://creativecommons.org/licenses/by-nc-nd/4.0/>).

Peer-review under responsibility of the scientific committee of the 8th International Conference on Applied Energy.

*Keywords:* Max 6 keywords Smart grid, bio-oil engine, wind turbine, solar power, energy storage units, supercapacitors

### 1. Introduction

A challenging future faced by the UK make the smart grid to be researched as a tremendous opportunity for solving energy crisis. Large amount of fund has been spend on the researching of the power generation networks [1]. For accessing higher efficacy of energy consuming, the power plant needs to be more flexible and more adaptable. Smart grid technologies combined with novel energy storage technology is a solution to the uncertainties of the power demand from the domestic energy demand.

With the ability of enabling new sources and new forms of energy demand to be integrated into one system, the smart grid is regarded as an efficient, timely and low carbon approach of energy supplying[2].

\* Corresponding author. Tel.: +447835151352  
E-mail address: [J.Ji2@newcastle.ac.uk](mailto:J.Ji2@newcastle.ac.uk).

Encouraged by the official supports and attracted by the smart grid’s future benefits, lots of researches accelerate the development of smart grid.

The smart grid technologies also refers to self-sufficient systems which are always prepared for an accident problem with corresponding solutions. Quickly response for the problems make the system to be more sustainable, reliable and stable. Lots of technological applications are applied in the smart grid by the researches and investor these days. Ali presents a control strategy for wide area smart grid architectural model. A time-variant load patterns was posted as complex problem for the model and a technical overview of data metering was surveyed in the research [3]. The results suggested the wide area smart grid model is a method to control and to operate similar systems.

Another key component of smart grid studies is the renewable energy [1]. Eltamaly shared an idea of optimal sizing of hybrid renewable energy systems [4]. In the research, the control problems and the optimization problems were considered with applying the renewable energy sources. By dividing the load into high priority load and low priority load, the system adjust its operation process to satisfy the load with different working patterns. As a result, the Matlab simulation confirmed that the size of the system could be reduced.

Many articles have researched the topic of smart grid. However, these articles lacked a comprehensive research on a small smart grid for varying domestic load. No research combined the renewable energy with the novel energy storage unit together with a smart grid system. This article addressed on the test process of a novel smart grid system. The controlling system is designed based on the SIEMENS S7-200 PLC model. Software has the function of measuring the performance of the system. The energy source of this system includes the generator sets, a wind turbine and solar panels combined as the energy source of this system. This system contains the function of DC energy transfer and AC energy supply that was different from a normal micro-scale energy generation. With a parallel energy source, the system has a serial of functions such as electricity generation, energy storage, transmission, control and protection, which guarantee the stability of this system. The inverters and converters are all connected with the data collector. With the connection of RS-485, the control centre could ensure the capacity of resisting disturbance. The results of the experimental tests indicate a high efficiency performance and a stable ability of supplying load.

## 2. System design and modellin

Figure 1 Configurations of system design

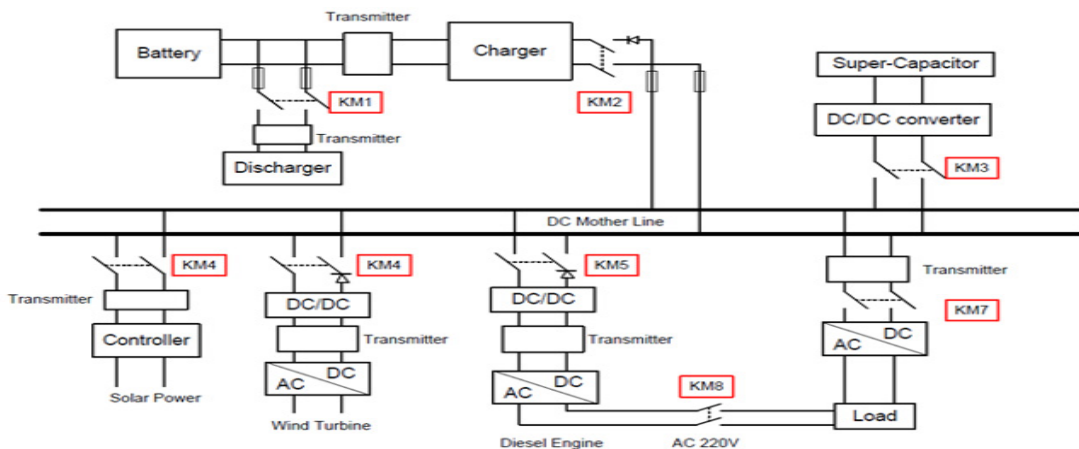

## 2.1 power generation system

The power generation system of this project consists of a bio-oil generator or wind turbine, a photovoltaic panel and electrical energy storage unit.

- Bio-oil generator
- The generator used in this test is driven by a bio-oil engine. The voltage of the generator could be adjusted during the operation.
- Solar panel energy generation
- Another electrical energy source of the system is solar panel. The solar panel is made of monocrystalline silicon solar cells which has 18% of energy transferring efficiency. The DC voltage of the panel is 36V. The rate power is 250W.
- Small scale wind turbine

The wind turbine applied in project is designed especially for the small scale smart grid. The AC power generated by the wind turbine will be injected in the AC/DC converter. Power from the turbine is connect on the DC mother line to be prepared for transmission. The energy supplied to the load is AC power from a DC/AC inverter which connected on the mother line.

## 2.2 energy storage unit

Energy storage unit is a significant part for the smart micro grid. In this project the energy storage units are made a combination of supercapacitors and storage batteries. The supercapacitors and the batteries are parallel connected. This kind of connection has advantages of enchantment of the system's ability of power releasing, reduction of the equipment wastage rate and enhancement of the system's working life.

## 3. Control strategy

### 3.1 Hardware structure

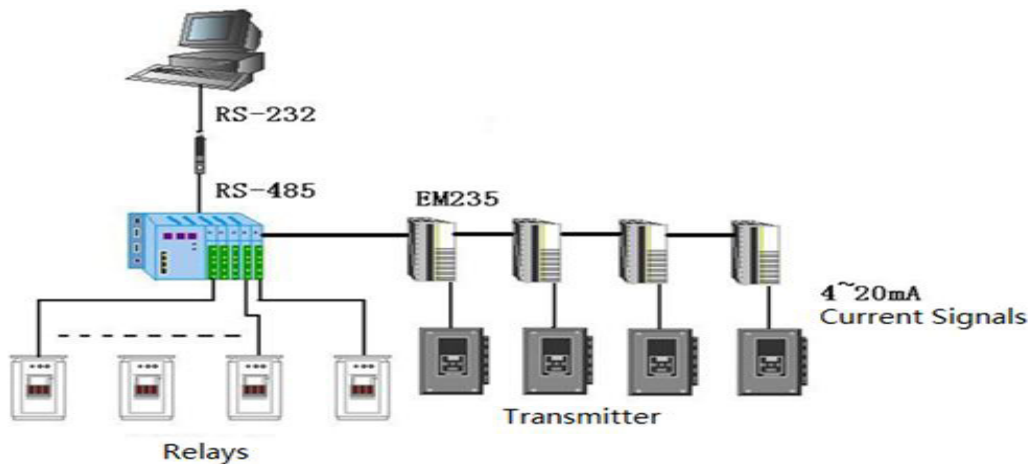

Figure 2 Controlling system combined with the signal displaying system.

As shown in Figure 4, the calculation of the controlling is done by using the model Siemens S7-200 PLC. The voltage and current signals are transported to the analog quantity, expanding unit-EM235 as a format of 4-20 mA current signal. After the processing of the signal, the PLC will send a command to control the system.

### *3.2 Features of the structure of the controlling system*

- S7-200 PLC as an individual controlling centre unit, the logic calculation, the analysis of the measuring signal and the command sending process are all processed in this unit.
- PC is operated as the inspection unit. The controlling command could be generated by the PC and the working state of the grid is displayed on the PC. The calculation is not implemented in this part.
- The connection between the PC and PLC is a signal cable with the connectors RS-232 and RS-485.
- The voltage and current signal measured on the system are transferred to analog signals and then transported to EM 235.
- The controlling system can operate individually, independent of the PC. The PLC is used for controlling all the equipment

### *3.3 System's controlling strategy*

In the operation of the same grid, the key point of the strategy is to balance energy resources and the energy demand. Once the unnecessary energy consumption is avoided, the maximum economic efficiency can be obtained. This research aims at designing and implementing adequate controlling by the approach of adjusting the working sequence of the switches in the system.

All the electrical equipment in the smart grid system can be controlled by the controlling switch from KM1 to KM 8. KM 8 prepares to stop the diesel engine's operation when a fault in fact occurs. The normal state of the switch KM 8 is off. The energy source in this project includes diesel engine, solar power and wind turbine. In this operation session, renewable energy is not applied. Different situations refer to various operation modes, and the details are presented. The first scenario is the operation strategy of this system without the renewable energy sources.

## **4. Experimental tests and results**

After a short starting time, the system is supervised by a monitor system. The system's operation conditions and the details of the parameters are displayed on the monitor screen. The figure shown below is the system's operation supervising screen. Under authority of the administrator, the system's power, current, voltage, switches and alarms can be observed and the results are recorded by the software. The primary test of this research is applying 0.31 KW pure resistance load. After applying the load, system is operating in normal mode with KM1, KM3 and KM7 closed. The primary test indicates the connection and function of the circle is qualified as designed.

### *4.1 Several scenarios are tested during the experimental work.*

When the discharge voltage of energy storage units is 58V, the discharge current is 5 A. The voltage of supercapacitors are 37V and the current is 14 A. On the load side, the AC voltage is 220V and the AC

current is 4A. The energy storage units discharge with a power of 290W and the supercapacitor could exceed 518 W in short time. The output power for supplying the load is over 800 W.

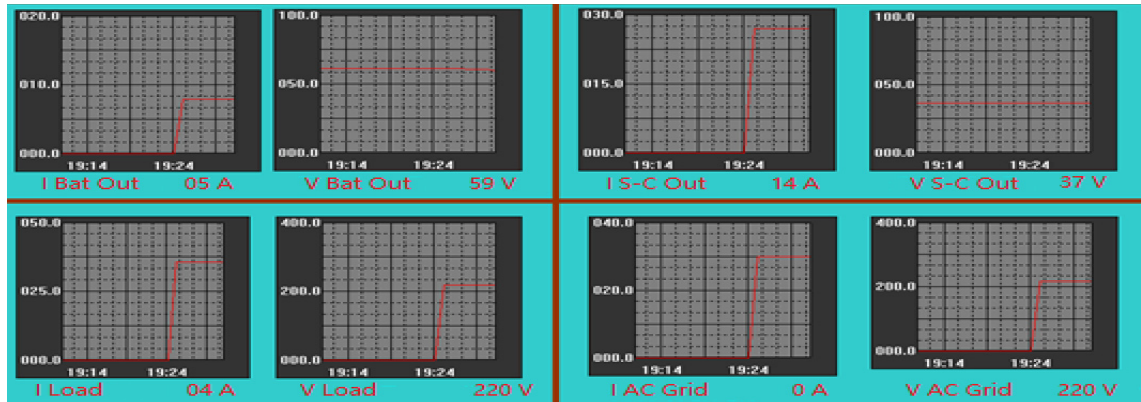

Figure 3 Monitor screen of 3 KW load

When a 3 KW load is connected in the system. The energy storage units is in charging mode. The bio-oil engine starts to generate the electricity for the system. Part of the electricity is used to charge the energy storage units. The rest of electricity generated is used to supply the load. At this moment, the DC voltage of the batteries is 58 V and the discharge current is 5 A. The supercapacitors has a 37 V discharge voltage. In this test, the energy generator is wind turbine. The overall efficiency of the energy supplying exceed 36.2%. The detailed monitoring information is shown in the figure 3.

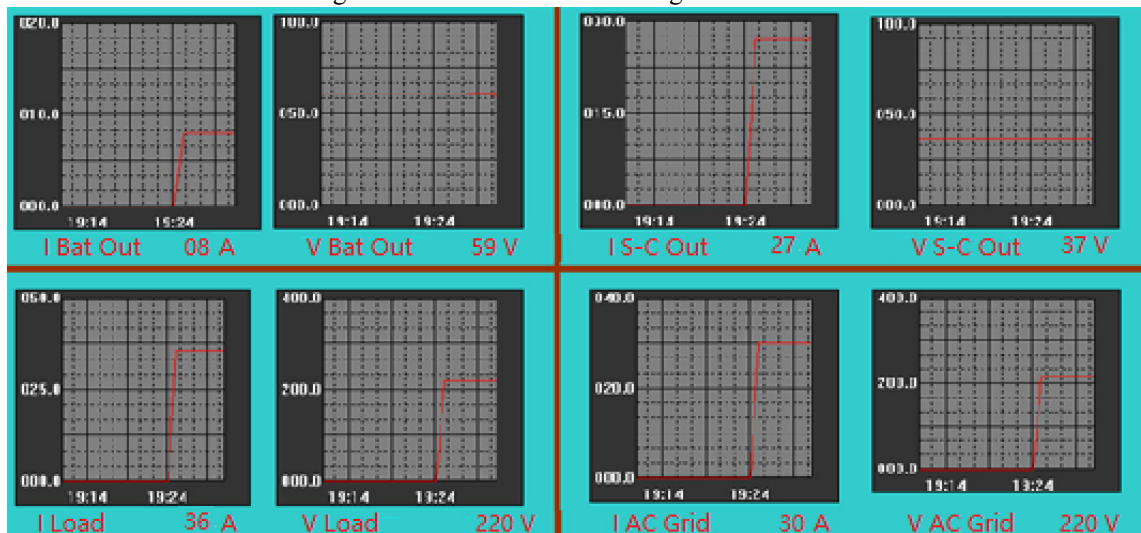

Figure 4 System monitoring screen of 4 KW load

When an 8 KW load is connected in the system. All the energy sources starts to supply the load. The discharge voltage of the batteries is 60V. The discharge current is 8 A. At the same time, the discharge voltage of the supercapacitors are 37V with a 27A discharge current. At the AC load side, 220V voltage

and 30A current shows the load is fully supplied by the system. The overall efficiency of the energy supplying exceed 39%. The detailed monitoring information is shown in the figure 4.

#### Consumption analysing

Based on the measured data, the energy consumption is summarised in the two tables below. The first table shows the value of the parameters during the 800 W load energy supplying process. The voltage and current of the energy storage is recorded. In this operation mode, the primary driver is not working. Only energy storage units supply the energy. Based on the calculation, the efficiency is 97.56%, the load could be satisfied by the energy storage unit.

Table 1 800 W test summary

	Current (A)	Voltage (V)	Power output (W)
Battery	6.5	59	383.5
Supercapacitor	14	37	518
Sub-total			902
Load	4	220	880
Efficiency			97.56%

Based on the measured data, the energy consumption is summarised in the two tables below. The first table shows the value of the parameters during the 8000 W load energy supplying process. In the table, besides batteries and supercapcitor 's operation detailed are displayed. For fulfilling the gap between the power rate of energy storage units and the energy demand, the engine also works during the 8 kW test. The operation details of the AC generator is also recorded due to engine's operation. According to the calculation shown in the table, the energy supplied reaches 8071 W and the energy demand is 7920 W. The energy efficiency is 98.13% in this case.

Table 2 8 KW test summary

	Current (A)	Voltage (V)	Power output (W)
Battery	8	59	472
Supercapacitor	27	37	999
AC Generator	30	220	6600
Sub-total			8071
Load	36	220	7920
Efficiency			98.13%

#### 4.2 Testing of a changing load



Figure 5 Monitoring of current on changing load

A long time changing load is added on the system's network. The current's changing is recorded by the software. As the figure 5 shown, the current of battery kept at a constant value at the test. At the same time, the current of the supercapacitor can change with fast to supplement the energy demand.

### 5. Conclusion

This smart grid system has a low-carbon design and an environment friendly operation mode. The purpose of this research is to evaluate the performance of the smart grid system. Following the designed control strategy for various energy demand supplying process. The operation conditions are recorded and analysed in the previous part. High level of automation is another advantage for this system. In the whole operation period, the controlling strategy implements automatically to make sure that the energy demand is satisfied with the smart grid. The carbon emissions are much lower than the similar system. The system strategy is proved to be reliable and stable. The overload, short circuit and circuit break are all considered in the controlling strategy. By applying this controlling strategy, the system can exceed high economic efficiency. Based on the scientific calculation, this strategy is an advanced operation strategy for this same grid system and the energy demand can be satisfied during all the tests.

For future work, the system is potentially to be applied in a multi energy system. The control strategy could also be improve since the energy demand is not as predictable as that in experimental tests. The power source could also be further controlled based on domestic energy consumption pattern. On the other hand, the graphene technology could be an alternative potential option for further optimization on the system.

### References

- [1] Hossain, M.S., et al., Role of smart grid in renewable energy: An overview. *Renewable and Sustainable Energy Reviews*, 2016. 60: p. 1168-1184.
- [2] Colak, I., et al., Smart grid projects in Europe: Current status, maturity and future scenarios. *Applied Energy*, 2015. 152: p. 58-70.
- [3] Ali, S.M., et al., Wide area smart grid architectural model and control: A survey. *Renewable and Sustainable Energy Reviews*, 2016. 64: p. 311-328.
- [4] Eltamaly, A.M., M.A. Mohamed, and A.I. Alolah, A novel smart grid theory for optimal sizing of hybrid renewable energy systems. *Solar Energy*, 2016. 124: p. 26-38.



### Biography

Jie Ji. PhD student of Swan centre in Newcastle University. Currently working in the project of Trigenation system studying and optimization.